

I.T. Kogut¹, T.M. Demyanchuk², M.D. Prokopiv²

Computer modeling of charge-discharge processes in series-connected sections in storage batteries

¹Department of Computer Engineering and Electronics, Vasyl Stefanyk Precarpathian National University, Ivano-Frankivsk, Ukraine, igor.kohut@pnu.edu.ua

²LLC "EMV-ENERGO" Research and Production Department of ACS TP Kyiv, Ukraine, tamataka@ukr.net

A theoretical analysis of the initial charge and discharge processes in consecutive connected sections of the battery under the action of rectangular pulses was carried out, in particular, their influence on the uniformity of energy accumulation and return was explored. The non-uniformity of energy accumulation and return between sections is shown. The equivalent electrical circuit of both single and serially connected battery sections is given. On the basis of equivalent electrical circuits, computer simulation of charge-discharge processes was carried out in the LT SPICE application program package.

Keywords: battery, serial connection of sections in a battery, modeling, charge-discharge processes.

Received 25 August 2023; Accepted 14 December 2023.

Introduction

Series connection of sections in storage batteries is widely used in various industries. Studies of the interaction of sections during charging or discharging of storage batteries are of interest because they help to extend their service life. The charge-discharge processes are described in the literature, in particular, in [1-5], and equivalent electrical circuits of one section of the storage battery (STB) are also given, as well as the processes that take place in each section of the STB during its charging. It was noted that when a voltage charging pulse is applied to the STB sections connected in series, there is a charge delay in each of the sections. However, the results of the effect of this delay on the energy storage in each of the sections are not given.

This work is dedicated to the actual analysis and research of the effect of the charge delay of each section of the STB on the amount of energy storage in the sections.

I. Theoretical analysis of the initial charge-discharge processes of series-connected storage battery sections.

The initial stage of charging. At the initial stage of charging, the current flows from the positive electrode, through the first section, to the negative electrode of the first section. At the same time, this process does not take place instantly, but with a certain delay due to both the initial arrangement of ions (positive and negative) and other processes.

Impulse methods are an effective method of charging STB [6-8]. In these methods, when a charging voltage pulse is applied at the moment t_0 , (Fig. 1) to the positive electrode of the first section, the charge current will flow through this section with a delay T_d , and at the moment of time t_1 will appear on the negative electrode of this section. That is, $T_d = t_1 - t_0$.

Similarly, the process will take place in the following sections of the STB. Let's consider these processes under the condition that all sections of the STB have the same parameters.

Then for the second section:

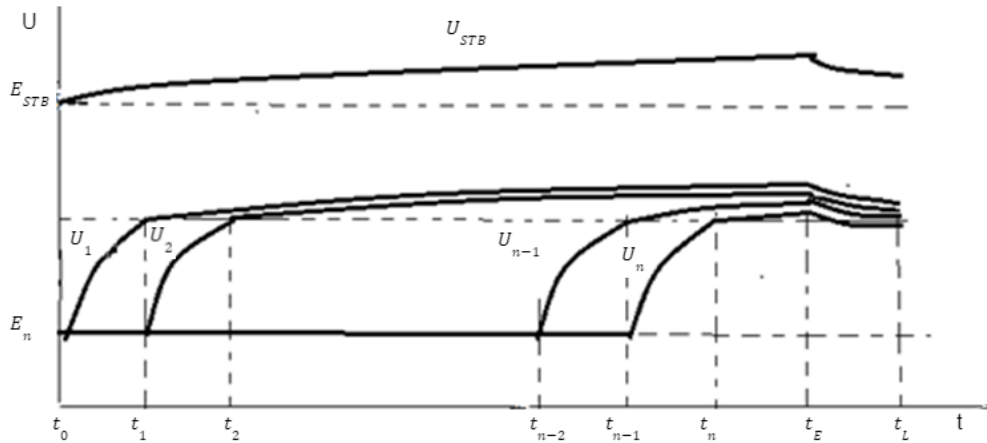

Fig. 1. Diagram of voltage change on the STB and on each section, during discharge.

$$T_d = t_2 - t_1.$$

For the n-section:

$$T_d = t_n - t_{n-1}.$$

The voltage U_n on each of the sections is:

$$U_n = E_n + \int f(e_n)de + R_n \int f(i_c)di$$

in the interval $T_1 = t_e - t_0$, in the interval $T_2 = t_e - t_1$ or the second section and similarly for the remaining sections.

That is, for the n-th section in the interval

$$T_e = t_e - t_{n-1}$$

where: E_n – electromotive force (EMF) on each of the sections before the start of charging, e_n – the value of the increase in electric current on each of the sections, during charging, respectively in the intervals T_1, T_2 and up to T_n , R_n – is the internal resistance of the STB section, i_3 – is the charging current in the same intervals, t_e – is the time when the STB charging is turned off. Therefore, the voltage on each subsequent section, except for the first, begins to increase with a delay of T_d (Fig. 1.).

After charging the battery, at the moment of time t_v , without load (no discharge current), in the interval $T_v=t_v-t_e$, the voltage on each of the sections is lower than the voltage at the moment of time t_e by the amount $R_n \int f(i_c)$.

Each of the sections accumulates energy during charging:

$$W_m = T_m \int f(i_c)(E_n + \int f(e_n) - R_n \int f(i_c))$$

where m – is the section number from 1 to n .

That is, in the interval $T_m = T_1$ for the first section, $T_m = T_2$ for the second, and likewise for the rest of the sections up to $T_m = T_n$ for the nth section. The first section will accumulate more energy than the second. This difference will be:

$$W_c = T_3 \int f(i_c)(E_n + \int f(e_n) - R_n \int f(i_c))$$

Similarly, in the second section, more energy is accumulated on W_c than in the third, and likewise in the following sections. And the n-th section will accumulate the least energy.

When $T_e \gg Tc_3$, where $T_e = t_e - t_n$, this difference in accumulated energy is not significant. But, with a large number of charge-discharge cycles of the STB, it accumulates and can affect the working condition of the STB sections.

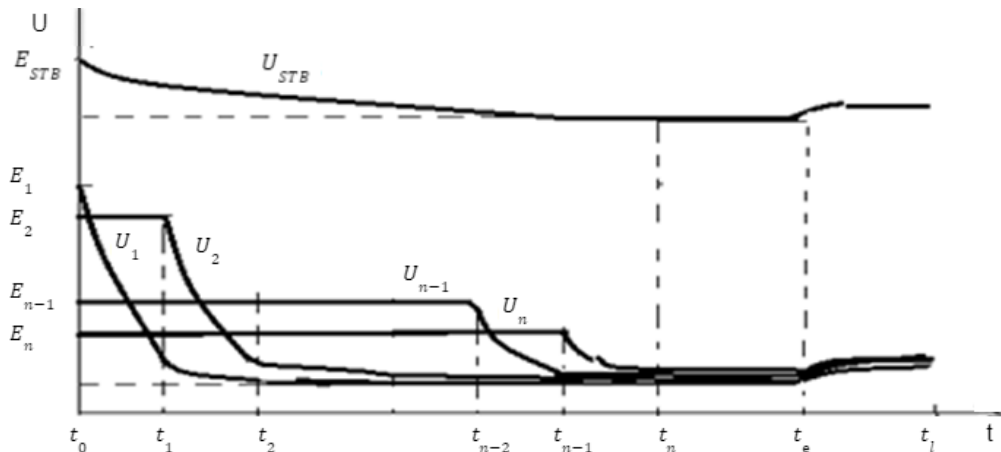

Fig. 2. Diagram of changes in voltage on sections and STB during charging.

The initial stage of STB discharge. When the STB is discharged with current i_r , in the initial stage, the current delay process in each of the sections is similar to that during charging. The discharge current flows from the positive electrode of the first section of the battery into the load, so the first section is activated first. We denote this delay as: $T_d=t_1-t_0$.

Similarly, the delay process will be in the following sections. For the second $T_d=t_2-t_1$, for the n th- section $T_n=t_n-t_{(n-1)}$.

The voltage for each of the n -sections is equal to:

$$U_n = E_b - \int f(e_p) - R_n \int f(i_p);$$

where: e_p is the magnitude of the electromotive force (e.m.f.) drop on each of the sections, during the discharge, respectively in the intervals T_1, T_2 and up to T_n , I_d is the discharge current in the same intervals, t_e – the time when the discharge (load) of the STB is turned off. The voltage on each subsequent section, except for the first, begins to decrease with a delay of T_d (Fig. 2).

After the end of the STB discharge, at the moment of time t_l , when there is no load in the interval $T_l=t_l-t_e$, the voltage on each of the sections is greater than the voltage at the moment of time t_e by an amount $R_n \int f(i_d)$

Each of the sections, during discharge, will consume energy:

$$W_m = T_m \int f(i_d) (E_b - \int f(e_p) - R_n \int f(i_d));$$

The first section loses energy more than the second, and this difference is equal to:

$$W_c = T_c \int f(i_d) (E_b - \int f(e_d) - R_n \int f(i_d));$$

And the n th- section will lose the least amount of energy.

After the end of the STB discharge, at the moment of time t_l , when there is no load in the interval $T_l=t_l-t_e$, the voltage on each of the sections is greater than the voltage at the moment of time t_e by the amount $R_n \int f(i_d)$.

Similarly, the second section will lose W_c more energy than the third, and so on in subsequent sections.

When $T_e \gg T_z$, this difference in energy consumption is not significant. But, with a large number of charge-discharge cycles of the battery, it can accumulate and affect the working condition of the sections.

II. Computer simulation of charge-discharge processes in the STB.

Computer modeling of charge-discharge processes was carried out in the LT SPICE application program package [9]. For this, based on the analysis of the known schemes for replacing the electrical circuits of the STB [10-12], an equivalent electrical circuit of both one section (Fig. 3.) and serially connected sections of the STB (Fig. 5) [13-16] was proposed, adapted for modeling in LT SPICE.

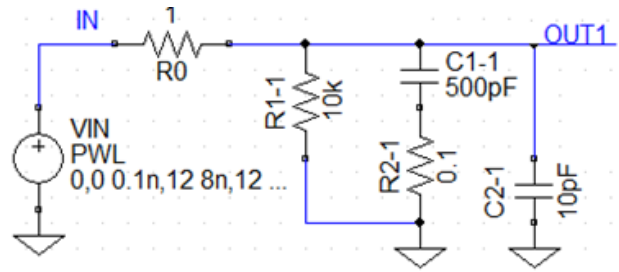

Fig. 3. Equivalent electrical scheme of charge-discharge of one section of the STB with a voltage pulse.

The equivalent electrical circuit contains the resistor R1-1, which is equivalent to the total resistance of the section, including the resistance of the loss currents, R2-1 corresponds to the internal resistance, and the capacitor C1-1 is the capacity of the battery section. Capacitor C2-1 simulates the initial delay of the charge current by the battery section. Resistor R0 is the equivalent resistance of the voltage source. Signals IN and OUT1, respectively, are the input and output signals of the VIN PWL source with a partially linear approximation of the description of the modeling signal. A rectangular pulse with a leading and trailing edge duration of 0.1 ns, a pulse duration of 8 ns, and an amplitude of 12V was set for simulation. The diagram shows the nominal values of the elements R0, R1, R2, C1 and C2, which were used in the simulation.

For the equivalent electrical circuit (Fig. 5), OUT1-OUT6 signals show the results of modeling the voltage time diagrams, respectively, on STB sections 1-6.

The equivalent electrical circuit contains resistor R1, which is equivalent to the total resistance of the section, including the resistance of loss currents, R2 corresponds to the internal resistance, capacitor C1 of the capacity of the STB section, and capacitor C2 simulates the initial delay of the charge current by the STB section. Resistor R0 is the equivalent resistance of the voltage source. Signals IN and OUT1, respectively, are the input and output signals of the VIN PWL source with a partially linear approximation of the description of the modeling signal. A rectangular pulse with a leading and trailing edge duration of 0.1 ns, a pulse duration of 8 ns, and an amplitude of 12 V was used for simulation.

The charging process takes place when the input voltage pulse VIN changes from 0 to 12 V in a time of 0.1 ns and at the top of the pulse with an amplitude of 12 V (quasi-constant voltage of the charging pulse for this example) and a duration of 8 ns. When the voltage of the input pulse changes from 12 V to 0 in a time of 0.1 ns (rear edge), the discharge processes of the STB section occur. Resistor R0, in addition to displaying the function of the internal resistance of the source, also electrically separates the nodes of the electrical equivalent circuit IN and OUT1, which obviously cannot be the same node of the circuit in the process of computer simulation.

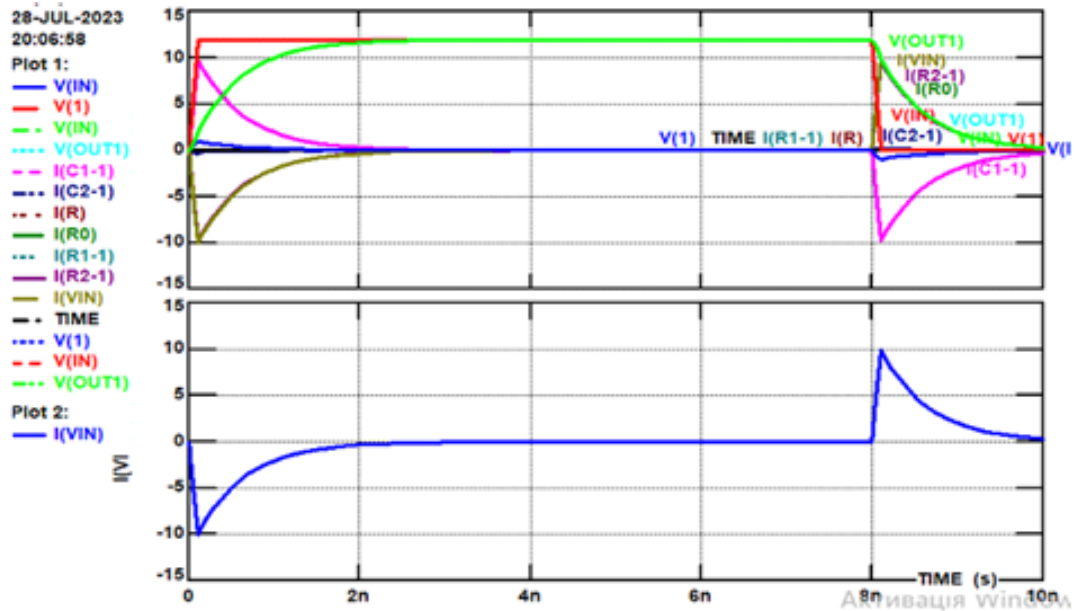

Fig. 4. Time diagrams of simulation of charge-discharge processes of one STB section.

The results of computer simulation of charge-discharge processes of one STB section in the form of time changes in voltage and transient processes in the form of changes in currents flowing through elements R1, R2 and C1 are shown in Fig. 4 (Plot. 1), and the total current of the transient process through the section is shown in Fig. 4 (Plot. 2). On the left in Fig. 4 are the designations of the curves of the time diagram.

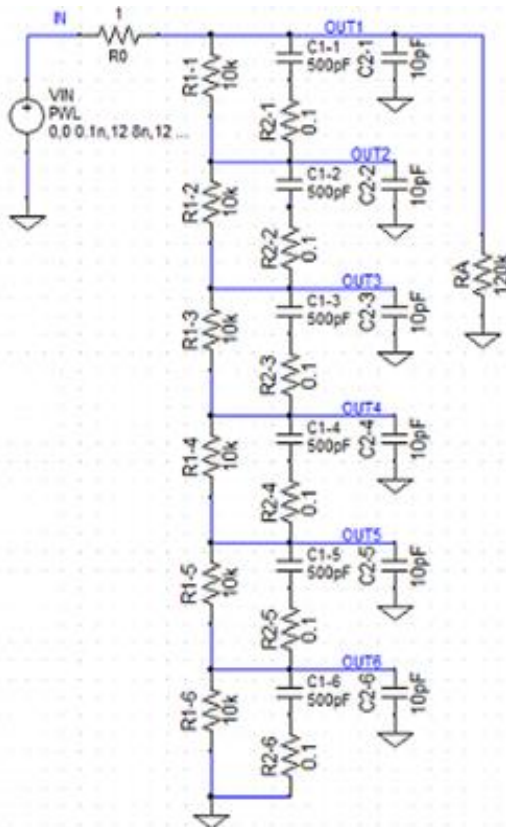

Fig. 5. Equivalent electrical circuit of charge-discharge of 6 consecutively connected STB sections by a voltage pulse (similar to a 6-section car battery).

The proposed equivalent electric circuit of the STB is convenient for evaluating the redistribution of voltages between sections during the charge-discharge process, when changing the parameters and characteristics of each section. For example, when the capacity of the second section C1-2 is changed by +/- 20%, namely, 600 and 400 pF, the voltage difference between OUT1 and OUT2, and OUT2 and OUT3 will be 2.2 V and 1.8 V, respectively. This indicates the deterioration of the operating conditions of individual STB sections and their negative impact on reliability. According to the results of computer simulation, for the same parameters of the sections of the equivalent electrical circuit of the STB, these voltage differences between all sections are also the same (Fig. 6). In addition to simulations using the voltage pulse generator V_{in} , simulations of one section of the STB from a constant voltage source VDD with the introduction of control n-channel MOSFETs - transistors M2 and M3 were also carried out. A simplified equivalent electrical circuit for simulating charge-discharge processes of one section of a STB with control MOS transistors is shown in Fig. 7.

The separation between charge and discharge processes is carried out by transistors M2 and M3 in such a way that when transistor M2 is open, then during this time period transistor M3 is closed. And these modes are specified by IN and IN-OUT signals, respectively. To obtain results similar to the previous ones, for this circuit the supply voltage VDD was 12.3 V, which is necessary to compensate for the voltage drop on the MOS transistor with a threshold voltage of 0.3 V. Such an element can be used to create integrated capacitive elements, e.g., sensor microsystems-on-a-crystal [17], for integrated capacitive voltage dividers, smoothing elements. To implement the elements of the control circuit in an integrated design, it is possible to use n-channel MOSFETs of both the standard type and those with "silicon-on-insulator" (SSI) structures, including their three-dimensional structures [18], polysilicon ones are optimal for resistors and capacitors films [19].

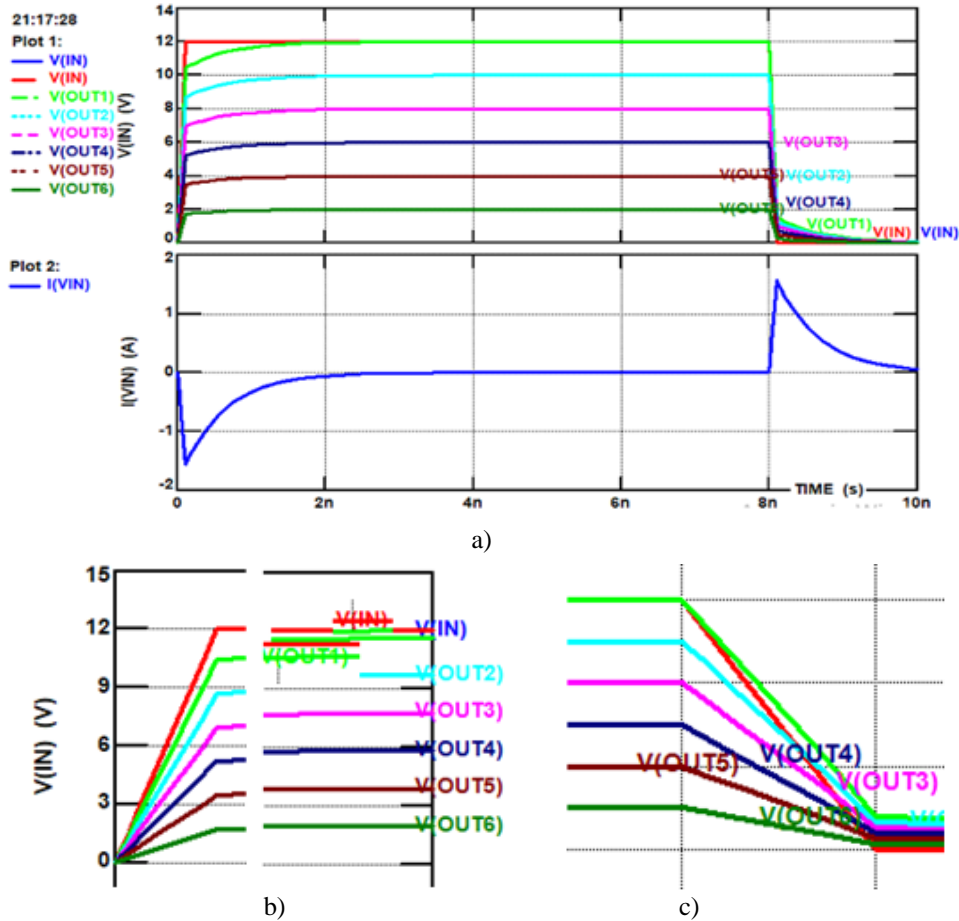

Fig. 6. Results of computer simulation of charge-discharge processes of series-connected 6 STB sections (a), Demonstration of the sequence of charge delays from section 1 to 6 (b), and the sequence of discharge delays from section 6 to 1 (c).

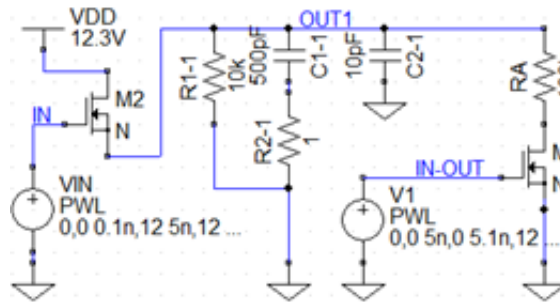

Fig. 7. Equivalent electrical circuit for simulating charge-discharge processes of the STB section with transistor control.

Conclusions

As a result of this research, the interaction of serially connected sections in storage batteries during their charging and discharging processes is shown.

It was noted that when a voltage charging pulse is applied to the STB sections connected in series, there is a charge and discharge delay in each of the sections. The effects of this delay on energy accumulation in each of the sections are theoretically analyzed. Since the amount of stored energy is also affected by the internal resistance of the section, partial compensation of uneven energy accumulation can be provided by selecting STB sections

according to internal resistance, in order of its decrease, from the first section to the next ones (Note: When assembling a Li-ion STB, the internal resistance is checked sections).

A capacitive-resistive equivalent electrical circuit is proposed for the analysis and computer modeling of charge and discharge processes both in a separate section of the STB and for sections connected in series. The results of computer modeling in the LT SPICE application program package confirm the presence of time delays for series-connected battery sections, and also show the redistribution of voltages between sections when their parameters are changed. The optimal mode of operation of the STB from series-connected sections will be provided with the same parameters of the elements of the equivalent

electrical circuit of each of the sections of the STB.

The obtained results can be useful in reliability studies and STB manufacturing, development of integrated capacitive elements as analogues of integrated micropower sources embedded in sensor microsystems-on-a-crystal.

Kogut I.T. – Doctor of Technical Sciences, Professor, Head of the Department of Computer Engineering and Electronics;

Demyanchuk T.M. – candidate of technical sciences, leading engineer;

Prokopiv M.D. – engineer.

- [1] O.M. Shembel, V.A. Bilogurov, *Basic characteristics of modern chemical current sources of various electrochemical systems*, Modern special equipment. Scientific and practical journal, 2(17), 66 (2009).
- [2] M.B. Shelest, P.I. Haida, *Basics of the structure and operation of storage batteries: teaching. manual* Ministry of Education and Science of Ukraine, Sumy. state University of Sumy: Sumy. state University, 2014. 210 p. fig. Bibliography: 183 (2014) —ISBN 978-966-657-530-5.
- [3] Corelamps, Blog, *Power sources*, <https://corelamps.com/dzherela-hyvlenia/akumuliator/Psychylenk>.
- [4] Web-source: Lithium-ion (Li-ion) batteries. Articles of the company “World Radio”: <https://radio-product.com.ua/ua/a260739-litij-ionnye-ion.html>.
- [5] Patent of China CN101510627B. Charging/discharging method for accumulator formation, formation method and device. Web-source: <https://patents.google.com/patent/CN101510627B/en>.
- [6] Patent of China CN101877425B. Web-source: Pulse container formation method for high-capacity lead-acid battery. <https://patents.google.com/patent/CN101877425B/en>.
- [7] Patent of China CN204216176U. Web-source: A kind of pulsed lead acid accumulator maintenance instrument. <https://patents.google.com/patent/CN204216176U/en>.
- [8] Simone Barcellona, Lorenzo Codecasa, Silvia Colnago, Luigi Piegari, *Cycle Aging Effect on the Open Circuit Voltage of Lithium-Ion Battery*, IEEE International Conference on Electrical Systems for Aircraft, Railway, Ship Propulsion and Road Vehicles & International Transportation Electrification Conference (ESARS-ITEC), 1-6, (2023); <https://doi.org/10.1109/ESARS-ITEC57127.2023.10114896>.
- [9] LTspice software. Web-source: <https://www.analog.com/en/design-center/design-tools-and-calculators/ltspice-simulator.html>.
- [10] Andrey Martyanov, Alexandr Gritsenko, Oksana Kostyuchenkova, *Model for Analyzing Battery Parameters as a Function of Ambient Temperature*, International Conference on Industrial Engineering, Applications and Manufacturing (ICIEAM), 119-124 (2021); <https://doi.org/10.1109/ICIEAM51226.2021.9446472>.
- [11] Alamgir Ahmad Khattak, Asad Nawaz Khan, Muhammad Safdar, Abdul Basit, Nauman Ahmad Zaffar, *A Hybrid Electric Circuit Battery Model Capturing Dynamic Battery Characteristics*, IEEE Kansas Power and Energy Conference (KPEC), 1-6 (2020); <https://doi.org/10.1109/KPEC47870.2020.9167659>.
- [12] Younes Boujoudar, Hassan Elmoussaoui, Tijani Lamhamdi, *Lithium-Ion batteries modeling using NARX Nonlinear model*, International Conference on Wireless Technologies, Embedded and Intelligent Systems (WITS), 1-6 (2019); <https://doi.org/10.1109/WITS.2019.8723705>.
- [13] Le Yi Wang, Feng Lin, Wen Chen, *Controllability, Observability, and Integrated State Estimation and Control of Networked Battery Systems*, IEEE Transactions on Control Systems Technology, 26(5), 1699 (2018); <https://doi.org/10.1109/TCST.2017.2727440>.
- [14] Roger C. Dugan, Jason A. Taylor, Davis Montenegro, *Energy Storage Modeling for Distribution Planning*, IEEE Transactions on Industry Applications, 53(2), 954 (2017); <https://doi.org/10.1109/TIA.2016.2639455>.
- [15] Tian Xia, Muye Li, Peng Zi, Liting Tian, Xiaohui Qin, Ning An, *Modeling and simulation of Battery Energy Storage System (BESS) used in power system*, 5th International Conference on Electric Utility Deregulation and Restructuring and Power Technologies (DRPT), 2120-2125 (2015); <https://doi.org/10.1109/DRPT.2015.7432597>.
- [16] Dongyi Zhang, Mahyar Zarghami, Tao Liang, Mohammad Vaziri, *A state-space model for integration of battery energy storage systems in bulk power grids*, North American Power Symposium (NAPS), 1-5, (2015); <https://doi.org/10.1109/NAPS.2015.7335179>.
- [17] I. Kogut, V. Holota, T. Benko, V. Pavlysh, Y Khoverko, *Simulation of Sensor Capacitive Elements Built into the Microsystem-On-Chip*. 2020 IEEE 40th International Conference on Electronics and Nanotechnology, ELNANO 2020 - Proceedings, 2020, pp. 211–215, 9088744.
- [18] I.T. Kogut, A.A. Druzhinin, V.I. Holota, *3D SOI elements for system-on-chip applications*, Adv. Mat. Res., 276, 137(2011); <https://doi.org/10.4028/www.scientific.net/AMR.276.137>.
- [19] A. Druzhinin, I. Ostrovskii, Y. Khoverko, I. Kogut, V. Golota, *Nanoscale polysilicon in sensors of physical values at cryogenic temperatures*, J. Mater. Sci: Mater. in Electron., 29(10), 8364(2018); <https://doi.org/10.1007/s10854-018-8847-0>.

I.T. Когут¹, Т.М. Дем'янчук², М.Д. Прокопів²

Комп'ютерне моделювання процесів заряду-розряду в послідовно-з'єднаних секціях в акумуляторних батареях

¹Кафедра комп'ютерної інженерії та електроніки, Прикарпатський національний університет імені Василя Стефаника, м. Івано-Франківськ, Україна, igor.kohut@pnu.edu.ua

²ТОВ «ЕМВ-ЕНЕРГО» Науково-виробничий департамент АСУ ТП м. Київ, Україна, tamataka@ukr.net

Проведено теоретичний аналіз початкових процесів заряду й розряду у послідовних з'єднаних секціях акумуляторної батареї під дією прямокутних імпульсів, зокрема, їх вплив на рівномірність накопичення і віддачі енергії. Показано нерівномірність накопичення і віддачі енергії між секціями. Наведено еквівалентну електричну схему як однієї, так і послідовно з'єднаних секцій акумуляторної батареї. На основі еквівалентних електричних схем, проведено комп'ютерне моделювання процесів заряду-розряду у пакеті прикладних програм LT SPICE. Результати комп'ютерного моделювання підтвержують результати теоретичного аналізу. Отримані результати можна використати для компоновки секцій в акумуляторних батареях, а також у розробках як зарядних пристроїв, так і приладів контролю стану акумуляторів.

Ключові слова: акумулятор, послідовне з'єднання секцій в акумуляторній батареї, моделювання, процеси заряду - розряду.