

V.V. Tsyhyka¹, I.I. Chychura¹, V.M. Rubish², R.O. Meshko¹

Thermal expansion of amorphous chalcogenide materials around their glass transition temperature

¹National University of Uzhhorod, Uzhhorod, Ukraine, volodymyr.tsyhyka@uzhnu.edu.ua

²Institute for Information Recording of the National Academy of Sciences of Ukraine

The patterns of thermal expansion of chalcogenide materials in the temperature range from room temperature to the beginning of deformation of the samples under the action of the measured force of the dilatometer cell were investigated. Above the glass transition temperature, the coefficient of linear thermal expansion of stabilized samples increases dramatically. For tempered glasses, the course of the temperature dependences of the relative elongation of the samples significantly depends on their thermal history and is of a complex nature. According to dilatometric measurements, the characteristic temperatures of the glass transition interval were determined, a qualitative assessment of structural changes was made depending on the temperature-time regimes of synthesis and annealing of chalcogenide glasses.

Keywords: chalcogenide glass, glass transition temperature, thermal expansion, structural relaxation.

Received 8 January 2024; Accepted 13 May 2024.

Introduction

As is known, vitreous materials are metastable supercooled melts in which, over time, changes in the structure and, therefore, in the physical properties of relaxation occur [1-8]. This metastability determines, in particular, the possibility of purposeful variation of glass properties depending on the temperature-time modes of synthesis and cooling of the melt.

The main goal of this work was to study the features of structural relaxation of glassy materials in the temperature range of glass transition. The publication deals with chalcogenide glasses, which are characterized by different ability to glass formation, with a low melting temperature and therefore represent a convenient object for studying structural changes around the glass transition temperature T_g . In addition, these materials are promising for use in optoelectronics and other fields [2], so studying the stability of their physical properties is of practical importance.

I. Experiment methodology

Research on thermal expansion was carried out for glasses of the binary composition As_2S_3 , as well as for samples of the quaternary system Ge-As-S-I(Br). As factors affecting the physical properties of samples of the same chemical composition, the change in the maximum synthesis temperature, melt cooling rates, and annealing temperature regimes were used.

The synthesis of glasses was carried out from the corresponding elementary components of purity in vacuumed quartz containers. The maximum temperature at which synthesis can still be carried out for quartz containers was 1320 K. The concentrations of the initial components were within 10 ÷ 20 grams. Samples for dilatometric measurements were cut from synthesized ingots, polished in the form of a parallelepiped with a height of 10 ÷ 12 mm and an area of opposite faces of 2x2 mm².

Measurements of the temperature dependence of the relative elongation $\Delta l/l(T)$ were carried out on a quartz dilatometer with a portable capacitive sensor. A feature of this automated device is a small measuring force on the

sample (no more than 0.3 N), which allowed measurements at temperatures above T_g , as well as the possibility of simultaneously recording the dependence of temperature on time and elongation of the sample from temperature. Features of the construction of the main components of the dilatometer - the capacitive converter and the temperature regulator - are given below, and are discussed more detail in [9, 10].

A flat capacitor consisting of a movable and fixed plate is used as a capacitive sensor. The minimum distance between the covers, therefore, and the initial capacitance C_0 , is determined by a thin layer of mica with a dielectric constant of $\varepsilon = 8$. The axial section of the dilatometer is shown in Fig. 1.

In the thin-walled cylindrical quartz housing 9, in the wall of which there is a hole for changing samples, a sample 13 is placed, resting on a quartz rod 7 with a movable electrode 3. The choice of fused quartz as a material for the measuring cell is due, first of all, to the fact that its coefficient of linear thermal expansion is almost an order of magnitude less than that of the studied samples. Spring 2, leans on the lower end of the rod, determines the measurable pressure on the sample.

A design feature of the holder 6 of the fixed electrode 5 gives the possibility of its free movement along the guides (not shown in the figure) during the replacement of the tested samples. This makes it possible to set practically identical capacity C_0 for samples of different lengths.

It is also possible to use a spring measuring head (micrometer) instead of spring 2, which makes it possible to calibrate the dependence of the change in capacity ΔC on the elongation of the sample Δx .

When the sample is elongated, we get a capacitor with a two-layer dielectric (mica and air). The replacement

scheme of this design is a series connection of two capacitors. We determine the equivalent capacity according to the ratio:

$$\frac{1}{C} = \frac{1}{C_0} + \frac{1}{C_x}$$

where $C_0 = \varepsilon\varepsilon_0 \frac{S}{\delta_0}$ and $C_x = \varepsilon_0 \frac{S}{x}$

Therefore, $C = \frac{\varepsilon_0 S}{\delta_0 / \varepsilon + x}$, where ε is the dielectric constant of mica, $\varepsilon_0 = 8.85 \cdot 10^{-12}$ F/m is the electrical constant, δ_0 is the initial distance between the covers, x is the elongation of the sample.

Thus, the considered design of the capacitive linear displacement converter allows setting the initial capacitance C_0 when replacing the samples, which makes it possible to minimize the measured force on the sample and ensures the calibration of the dependencies $\Delta C(x)$.

Heating was controlled by a temperature controller that implements the proportional-integral-differential regulation law. Since high-precision temperature control systems are used in many industries and, especially, in scientific research, a wide range of temperature control devices has been developed [10, 11]. For precise regulation, i.e., minimization of the influence of transient processes, the accuracy of tracking the given temperature regime, a careful adjustment of the transfer function $W(p)$ of the regulator (where p is the Laplace transformation operator) is required, which is carried out by selecting appropriate coefficients dependent on many factors, in particular, from the set temperature.

Simplifying the process of setting the function $W(p)$ allows the use of computer systems in which the microprocessor performs the functions of both a

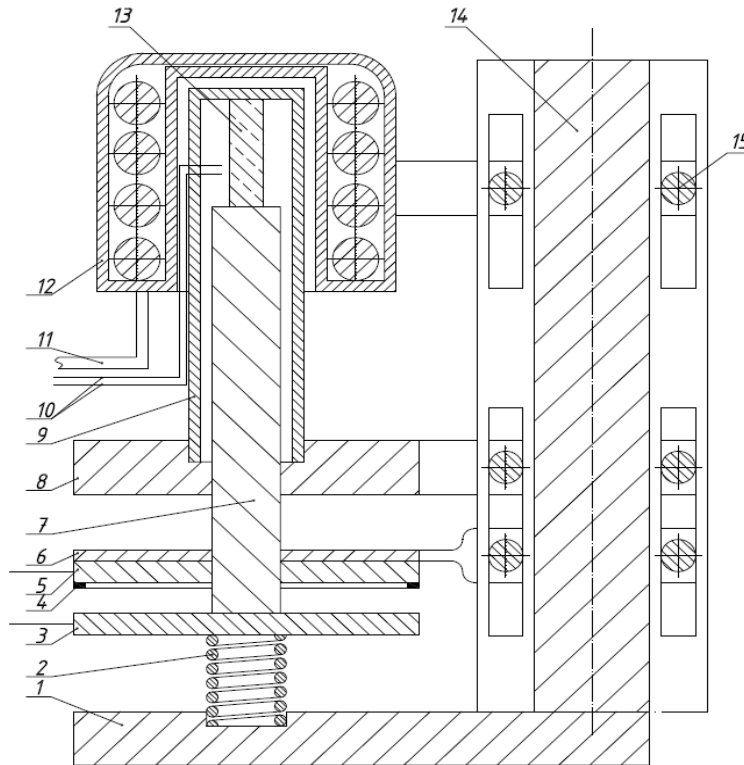

Fig. 1. Section of the dilatometer: 1 – support bottom, 2 – spring, 3 – movable electrode, 4 – mica gasket, 5 – fixed electrode, 6 – fixed electrode holder, 7 – quartz rod, 8 – movable housing support, 9 – housing, 10 – thermocouple output, 11 – cable, 12 – heater, 13 – sample, 14 – supporting shaft, 15 – fastening bolt.

comparison and a correction element based on information about the state of the object received through feedback channels and performs automatic heating regulation according to a given program.

With the obvious advantages of a microprocessor system, appears the problem of developing and debugging the appropriate software arises, which is often a difficult task to achieve. At the same time, in many scientific studies, for example, in differential thermal analysis, dilatometry requires the adjustment of the temperature of low-inertia heaters according to the linear heating law with speeds that are, as a rule, fractions and units of degrees per minute [7]. In this case, there is no need to use microprocessor systems that are complex in terms of software.

Most of the universal thermostats implement the mode of stabilization of the set temperature [11]. It is represented by a dilatometer uses a digital device that expands the functionality of such regulators and provides the possibility of linear heating and cooling at different speeds. It is a linear-alternating voltage generator (LAVG) with a controlled sweep time of the output signal, which is used as a power source for the setting device thermostat. The functional circuit of LAVG includes a generator of clock pulses, a frequency divider, a reversible binary counter, a digital-to-analog converter and a code generator for setting the clock frequency division coefficient. The output voltage of the LAVG is supplied to the input of the setting device of the precision temperature regulator. The frequency of pulses entering the meter input determines the temperature control program. The reference direction (addition, subtraction) determines the mode of heating or cooling. When the passage of clock pulses is blocked, the set temperature is stabilized.

Therefore, two signals are received at the inputs of the temperature regulator - one from the setting device of this regulator, the other from the thermocouple, the working junction of which is located near the coil of the heating winding of the electric furnace. The magnitude of the imbalance between these two voltages determines the magnitude of the current on heater winding. The considered automatic regulation system, which is consisting of a precision temperature regulator and a heating element, provides linear heating and cooling with speeds within $0.1 \div 10$ degrees/min., as well as stabilization of the set temperature.

II. Experimental results

Dilatometric studies have shown that the nature of the dependences $\Delta l/l(T)$, where Δl is the absolute elongation, l is the initial length of the sample, reveals a number of general regularities that depend on the temperature history and crystallization ability of the glasses. The criterion of the latter can be the preservation of the glassy state after prolonged annealing and, conversely, crystallization at low heating rates, in particular, in the process of differential thermal analysis (DTA). Illustrative material in this work is given for samples hardened from the synthesis temperature and annealed at temperatures close to T_g .

As an example, Fig. 2 shows typical temperature

dependences of the relative elongation of annealed glasses of the Ge-As-S-Br system along the section $(\text{GeS}_2)_x(\text{AsSBr})_{100-x}$. The elongation of all samples is practically linear in the temperature range from 300 K to the glass transition temperature T_g . At temperatures above T_g there is a jump-like increase in the coefficient of linear thermal expansion (CLTE) $\alpha = \Delta l/(l \cdot \Delta T)$, and subsequently plastic deformation of the samples under the action of the measured force of this dilatometric cell.

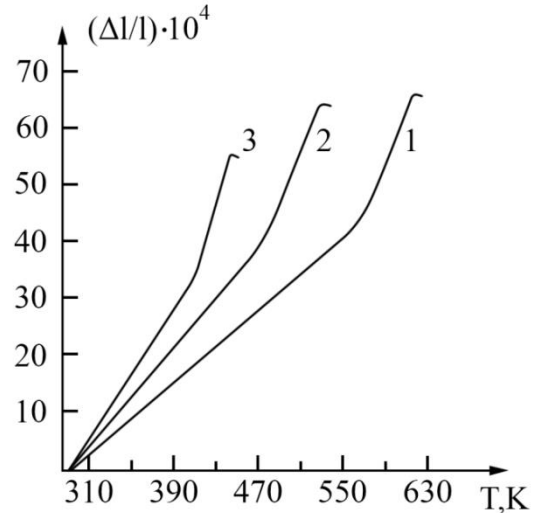

Fig. 2. Temperature dependences of relative elongation of annealed glasses $(\text{GeS}_2)_x(\text{AsSBr})_{100-x}$:

1 – $(\text{GeS}_2)_{80}(\text{AsSBr})_{20}$; 2 – $(\text{GeS}_2)_{60}(\text{AsSBr})_{40}$; 3 – $(\text{GeS}_2)_{40}(\text{AsSBr})_{60}$.

For tempered or insufficiently annealed glasses, a sharp decrease in relative elongation occurs already at temperatures $\sim (0.65 \div 0.85) \cdot T_g$. At speeds of linear heating of the samples of the order of $q = 1.0$ degrees/min, in a number of cases their relative elongation decreased during the heating process (Fig. 3).

The interpretation of temperature dependences $\Delta l/l$ is possible within the framework of the relaxation model of vitrification, which operates, in particular, with the concept of structural temperature T_s , which is the temperature of the metastable melt, the structure of which is fixed in this glass [1]. According to this approach, the reduction in elongation of tempered glasses occurs as a result of relaxation processes of structure stabilization, provided that the relaxation time τ is proportional to the observation time. In the process of cooling the melt, a continuous spectrum of metastable structures is formed, the stabilization of which is determined by the corresponding continuous spectrum of relaxation times [1]. Relaxation is a thermally activated process, and τ is proportional to the glass viscosity η [2]. Since structural changes in the temperature dependence of the relative elongation of the glasses of the Ge-As-S-Br system are identified at temperatures $\sim (0.65 \div 0.85) T_g$ (quenching) and T_g (annealing), it should be assumed that at these temperatures the values of both the activation energy of relaxation processes and the viscosity of samples with different thermal history match with each other.

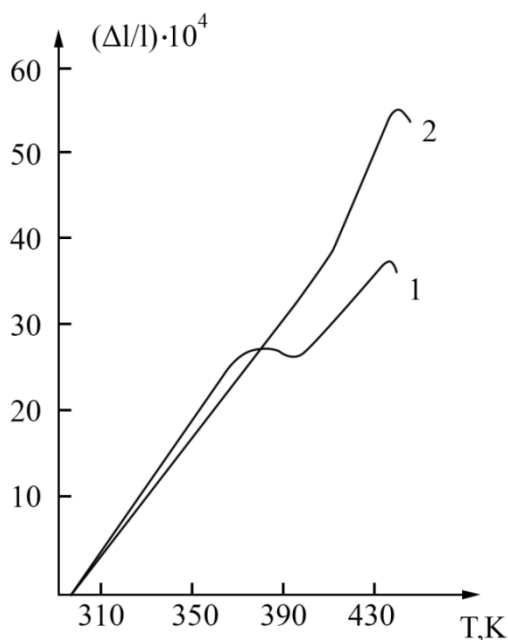

Fig. 3. Thermal expansion of glass composition $(\text{GeS}_2)_{40}(\text{AsSBr})_{60}$: 1 – the sample is cooled from the synthesis temperature of 1120 K in the quenching mode; 2 – annealed sample.

The glass transition temperature should be considered as the minimum structural temperature T_{smin} , which can be determined experimentally for stabilized (ie, annealed) glasses. Temperature $T_a = k \cdot T_g$, where the coefficient $k < 1$, at which the viscosity η of the tempered sample decreases to the value when the relaxation processes of structural changes are activated to the same extent as it happens for annealed samples when heated to the glass transition temperature T_g , is the lower limit of the glass transition interval, which can be identified, in particular, on the dependences $\Delta l/l(T)$. Note that in many publications the parameter T_g [3] is taken as the lower limit of the glass transition interval, which is incorrect for glasses synthesized in the regime of high melt cooling rates, since for tempered glasses the activation temperature of the structure stabilization processes is $T_a < T_g$ and depends on the achieved degree of metastability.

For vitreous samples, which can be obtained only in the quenching mode, the processes of structure stabilization in the glass transition region tend to order, and the structural temperature T_s decreases. As a result of structural relaxation, when such samples are heated, their specific volume may decrease. On the dependences $\Delta l/l(T)$ it is manifested in the form of a decrease in the relative elongation of the samples as the temperature increases (Fig. 3).

For glasses of different compositions, a study of the influence of the maximum synthesis temperature and the cooling rate of the melt on thermal expansion was carried out. In particular, glasses of the As-S systems, Ge-As-S-Br was cooled from temperatures in the range from 870 K to 1320 K in different modes. For samples of identical chemical composition, different CLTE values were obtained, but the subsequent heat treatment in the glass transition interval determined the nature of the curves $\Delta l/l(T)$.

It is of interest to compare the results of dilatometric measurements of the characteristic temperatures of the glass transition interval with DTA measurements. The corresponding dependences are shown in Fig. 4 for glassy As_2S_3 samples with different thermal histories.

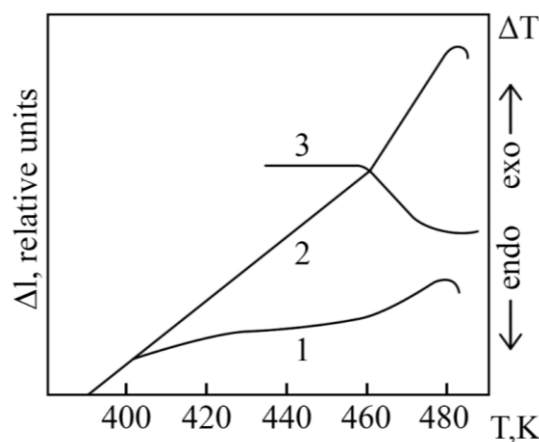

Fig. 4. 1 – temperature dependence Δl (in relative units) for As_2S_3 glass obtained in the tempering mode; 2 – $\Delta l(T)$ of the annealed sample; 3 – DTA curve for sample 2.

For the annealed samples, the beginning of the endothermic effect on the DTA curves, caused by softening, and correlates with T_g , determined from the dependences $\Delta l/l(T)$. For hardened samples, deviations of the DTA curve from the baseline, which would allow reliable identification of thermal effects in the glass transition interval, were practically not observed. Perhaps the observation of such a phenomenon in this type of thermal analysis requires correlation of the rate of heating of the samples with the corresponding times of structural relaxation.

Conclusions

Dilatometric measurements at linear heating rates, which are correlated with the rate of structural relaxation processes of the studied samples in the glass transition interval, have applied value, first of all, for determining the upper temperature limit of reliable operation of device elements that include glassy materials.

The temperature dependences of the relative elongation of the samples $\Delta l/l(T)$ make it possible to make unambiguous conclusions about the thermal history of the samples, to optimize the temperature-time regimes of annealing glassy materials, and to correctly determine the glass transition temperature.

The glass transition temperature T_g can be defined as the minimum structural temperature of stabilized (annealed) glass. Experimentally, T_g can be measured only for annealed samples. For such glasses, T_g , determined by various methods (dilatometry, DTA, differential scanning calorimetry), and should match.

For tempered glasses, the lower temperature limit of the glass transition interval T_a decreases in proportion to the achieved degree of metastability. In particular, for chalcogenide glasses obtained in the cooling mode with

the maximum speed, the activation of structural relaxation processes is identified on the dependences $\Delta l/l(T)$ already at temperatures $T_a \approx (0.65 \div 0.85) \cdot T_g$.

The intensity of restructuring of the structural network of hardened samples leads to the appearance of temperature areas where the relative elongation of the glass decreases during the heating process, and the CLTE drops to zero and even takes negative values.

Tsyhyka V.V. – associate professor of the Department of Instrument Engineering of Uzhhorod National University, a candidate in physical and mathematical sciences;

Chychura I.I. – Head of the Department of Instrument Engineering of Uzhhorod National University, a candidate in physical and mathematical sciences;

Rubish V.M. – Head of Uzhhorod Laboratory of Optoelectronics and Photonics Materials of the Institute for Information Recording of the National Academy of Science of Ukraine, doctor of physics and mathematics sciences, professor;

Meshko R.O. – Senior lecturer of the Department of Instrument Engineering of Uzhhorod National University.

- [1] V. V. Petrov, A. A. Kryuchin, V. M. Rubish. *Materials promising optoelectronic devices* (Naukova dumka, Kyiv, 2012).
- [2] O. V. Stronskyi, H. M. Telbiz, P. F. Oleksenko. *Properties and applications of chalcogenide glasses. Pt. I (review)*, Optoelektronika i napivprovodnykova tekhnika, 48, 30 (2013).
- [3] T. B. Zheplynskyu, *Features of change of thermophysical properties in the glass transition interval*, Chemistry, Technology and Application of Substances, 2(2), 62 (2019); <https://doi.org/10.23939/ctas2019.02.062>.
- [4] V.V.Tsyhyka, I.J.Rosola, I.I.Turianitsa, M.V.Tsyhyka. *Possibilities for use of dilatometry for identification of nanostructural changes in vitreous materials*. Materials of the Int. Meeting “Clusters and nanostructured materials” (CNM-5) – Uzhgorod Vodograj Ukraine, 286 (22-26 October 2018).
- [5] I. J.Rosola, V.V. Tsyhyka. *Influence of conditions on obtaining linear expansion and structure of vitreous As(2)S(5)*, Scientific Herald of Uzhhorod University, series "Physics", 28, 57 (2010).
- [6] V.S. Bilanych, V.B. Onyshchak, I.M. Rizak, K. Csach, K. Flachbart, V.M. Rizak. *The investigation of the glasses GexAsySe100-x-y by differential scanning calorimetry method*, Scientific Herald of Uzhhorod University, series "Physics", 25, 24 (2009).
- [7] V.V. Tsyhyka, I.I. Turianytsia. *Teplove rozshyrennia i strukturna relaksatsiia u neorhanichnykh steklakh*, UFZh., 42(11-12), 1377 (1997).
- [8] V.V. Tsyhyka, I. J. Rosola, I. I.Chychura, M.V.Tsyhyka. *On the structural relaxation of chalcogenide vitreous materials*, Journal of Optoelectronics and Advanced Materials, 26, (1-2), p. 54 (2024).
- [9] V.V. Tsyhyka, M.M. Rjaboschuk. *Capacitive linear displacement transducer*, Actual scientific research in the modern world, International science journal, 4(96), 186 (2023).
- [10] V.V. Tsyhyka. *Temperature regulator for linear heating*, Actual scientific research in the modern world. International science journal, 4(96), 183 (2023).
- [11] PID regulators [Electronic resource]. Access mode: <https://ukrspecavtomat.com.ua/uk/products-category/pid-regulatory>.

В.В. Цигика¹, І. І. Чичура¹, В. М. Рубіш², Р.О.Мешко¹

Термічне розширення аморфних халькогенідних матеріалів в околі температури склування

¹ДВНЗ «Ужгородський національний університет», м. Ужгород, Україна, volodymyr.tsyhyka@uzhnu.edu.ua

²Інститут проблем реєстрації інформації НАН України, м. Ужгород, Україна

Досліджено закономірності теплового розширення халькогенідних скловидних матеріалів в інтервалі температур від кімнатної до початку деформації зразків під дією вимірного зусилля комірки дилатометра. Вище температури склування коефіцієнт лінійного термічного розширення стабілізованих зразків стрибкоподібно зростає. Для загартованих стекол хід температурних залежностей відносного видовження зразків суттєво залежить від їх термічної передісторії і носить складний характер. Згідно дилатометричних вимірювань визначено характеристичні температури інтервалусклування, здійснено якісну оцінку структурних змін в залежності від температурно-часових режимів синтезу і відпалу халькогенідних стекол.

Ключові слова: халькогенідне скло, температура склування, теплове розширення, структурна релаксація.