

PACS: 47.60.-i

ISSN 1729-4428 (Print)
ISSN 2309-8589 (Online)

I.R. Vashchysyak¹, S.P. Vashchysyak², T.M. Mazur¹, M.P. Mazur¹

Study of the influence of the environment on the efficiency of induction heating of low-temperature heat pipe

¹*Ivano-Frankivsk National Technical University of Oil and Gas, Ivano-Frankivsk, Ukraine, tetiana.mazur@nung.edu.ua*
²*King Danylo University, Ivano-Frankivsk, Ukraine*

The influence of ferromagnetic materials of three cylindrical structural steel cores and a spiral weave magnetic stainless-steel core on the efficiency of induction heating of the coolant in a low-temperature oppression heat pipe is investigated. Two cores were intended for use under the oppression layer, and two - behind the oppression layer made of stainless mesh without magnetic properties. The efficiency of induction heating using a cylindrical coil wound on the surface of the tube was studied. An experimental setup was assembled from a heat pipe, a cylindrical induction coil put on its lower part, a pulse generator, an amplifier, a power switch, a wattmeter, two thermocouples and a timer. Experiments have shown that at a low frequency of heat pipes with a vertical orientation, with a decrease in the wall thickness of the iron cylindrical core and an increase in its radius, the efficiency of induction heating increases. For heat pipes with arbitrary orientation in space, the highest efficiency of induction heating is provided by a cylindrical thin-walled single-layer core placed after the oppression layer. But the highest operational reliability and high efficiency of induction heating can be provided by a solid cylindrical core, or a spiral-weave core made of magnetic stainless steel AISI 430 or 439, wound on a heat-resistant plastic frame with holes for the coolant movement. The maximum radius and minimum mass of the core should provide the highest intensity of heating of the coolant per unit of time.

Keywords: heat pipe, induction heating, core, coolant, frequency, power.

Received 18 May 2024; Accepted 18 November 2024.

Introduction

Thermosiphons and oppressive heat pipes are highly efficient heat exchangers with very high thermal conductivity coefficients and minimal surface heating time [1,2]. Due to this, their surface has a minimal temperature difference along the entire length, which allows them to be used as elements for rapid heating of certain zones [3,4], temperature equalizers, elements for local heating [5], cooling [6], space heating [7,8], etc. Unlike thermosiphons, which operate effectively in a position close to vertical [2,9], heat pipes can operate effectively at any angle of inclination due to the presence of various types of oppressions [10-12] and working fluids [13-15], which significantly expands the areas of their application [16-19].

One of the promising applications of heat pipes may be their use as low-temperature heat sources for warming

the human body. Most devices intended for this purpose (for example, heated blankets, electric blankets) are powered by a 220 V network, which makes their operation impossible during periods of power outages associated with the emergency state of energy facilities because of military operations. When the power is turned off, people use batteries and power banks, which can serve as energy sources for heating low-temperature heat pipes.

Let's determine whether the power of these devices is sufficient to power the tubes. On average, a person consumes about 100 W of energy to maintain basic vital functions at rest. Let's assume that it is necessary to increase the body temperature by 1 °C. For an approximate calculation, we will use the well-known formula for calculating the amount of heat, where we assume that the body mass $m = 80$ kg, the average heat capacity of the body $c = 3500$ J/(kg °C), the change in temperature $\Delta T = 1$ °C. Then the amount of heat

$Q = 80 \cdot 3500 \cdot 1 = 280000 \text{ J}$. Converting joules into watts (where $1 \text{ W} = 1 \text{ J/s}$), we get $280000 \text{ J} / 3600 \text{ s} \approx 77.8 \text{ W}$.

Therefore, 7-8 heat pipes with a power of about 10 W can warm the average person. Considering that the heat pipes should be placed in a sleeping bag or other heat-insulating material with low heat loss, this power may even be too much. That is, a medium-power 12 V battery or a powerful power bank will provide warming for a person for several hours, during which the power outage continues. To do this, it is necessary to develop a heat pipe with an effective coolant heating system and a simple and reliable control system.

The temperature and efficiency of a heat pipe directly depend on the type of energy source connected to its lower end. The lower end of a heat pipe can be heated in different ways: by immersing it in a flow of heated liquid, by connecting a nichrome or ceramic heater to it, or by induction. The method of immersing the lower end of a heat pipe in a collector with a heated liquid flow ensures rapid heating and high efficiency of the tube due to almost complete heat transfer by the flow, but requires additional pipelines, a liquid heating system, a pump, and an electronic control system [20]. The heating method using a nichrome wire was highly efficient [21], but over time showed low reliability due to a change in the area of the electrical contact due to overheating and oxidation of nichrome. The heating method using a ceramic heater only requires an on/off system, but somewhat reduces the efficiency of the tube due to the presence of a multilayer structure through which the heat flow is transferred (heater – thermal paste – aluminum dampers – thermal paste – tube surface). The main disadvantages of the method are the need to control the power of each ceramic heater, a decrease in heat flow over time due to the gradual degradation of dampers and thermal paste, and low practical reliability of the heaters themselves [22].

The described methods involve external heating of the heat pipe, which results in a loss of a certain amount of heat from the source of dissipated energy into the environment.

I. Elements of the theory

In our opinion, heating the coolant directly inside the heat pipe using induction heating is promising [23,24]. Induction heating has many advantages. Firstly, by selecting the length and diameter of the induction coil wire, it is possible to set the required current, voltage and thermal power of the tube. Secondly, the coolant is heated directly inside the tube, which significantly increases the speed of temperature gained by the tube. Thirdly, the surface of the tube serves as a radiator for the induction coil and prevents it from overheating [25].

Induction heating of the lower end of a heat pipe can be achieved in two ways (Fig. 1): by installing a flat spiral coil at the end of the tube with a flat round core with ferromagnetic properties inside the tube opposite the coil (Fig. 1, a) and by installing a cylindrical coil at the bottom of the heat pipe with a cylindrical core made of magnetic material inside the tube (Fig. 1, b).

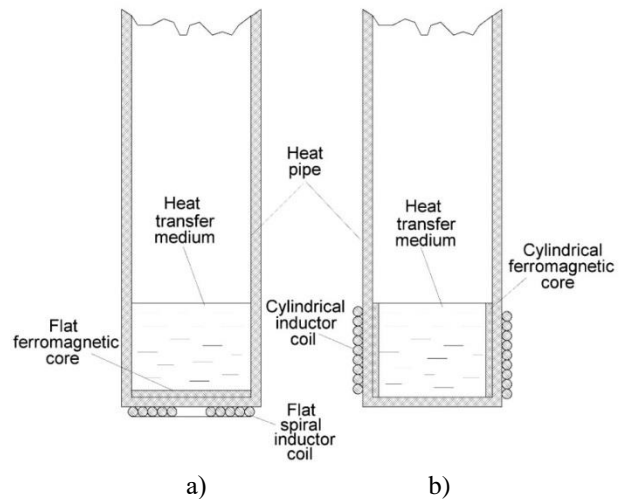

Fig. 1. Methods of using induction heating of the coolant in a heat pipe: a) using a flat coil, b) using a cylindrical coil.

The first method (Fig. 1, a) is more effective, since the area of the flat round core is small and it has low thermal inertia, which leads to rapid heating of the coolant. However, its implementation encounters significant technical difficulties associated with the complexity of manufacturing and installing a very small flat spiral coil, high operating frequencies, the complexity of tuning resonant circuits, and the need for a complex small-sized control system. This requires additional intensive removal from the system elements, which significantly reduces its reliability.

The implementation of the second method of induction heating of the coolant (Fig. 1, b) is technically more attractive, since it is quite simple to manufacture a cylindrical coil and core, and the operating frequencies of the coil can be low. This will not lead to heating of the control system elements, will simplify its design, will allow minimize the dimensions and increase reliability.

This work is devoted to the study of the efficiency of induction heating using a cylindrical coil.

II. Experiment

2.1. Research Objects

A copper heat pipe with a diameter of 18 mm, a wall thickness of 1 mm and a length of 50 cm was used for the research. A layer of wick made of stainless-steel mesh with a thickness of 1 mm was installed in the pipe. Separately, the heat pipe contained a sealed input in the upper part, through which the wires of the thermocouple were placed in it, which was installed at the level of the liquid – the coolant.

The view of the lower part of the experimental tube with an induction coil is shown in Fig. 2. A single-layer cylindrical induction coil was wound on a two-layer insulating base (heat-resistant paint and a layer of thermally conductive paste) with copper wire of 0.25 mm in diameter. The coil had a diameter of 20 mm, a length of 30 mm and was placed in the lower part of the experimental tube. A radiator with a power key for controlling the coil was placed near the coil on thermal insulators.

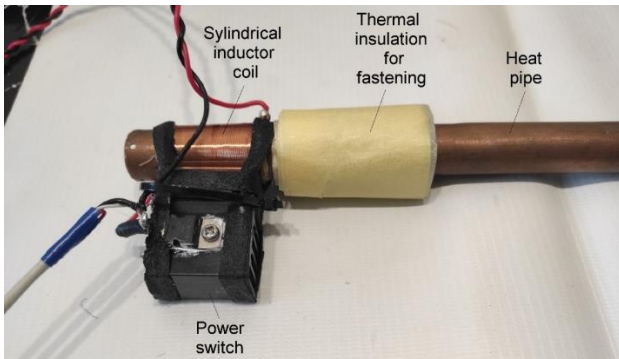

Fig. 2. View of the lower part of the experimental tube with an induction coil.

To conduct the experiments, 4 cores were made of ferromagnetic steels without pronounced frequency properties, the parameters of which are given in Table 1.

The appearance of the cores is shown in Fig. 3. Core 1 is made of spiral weaving and placed in a heat-resistant plastic capsule with holes for the coolant movement. The other cores are cylindrical and made of sheet steel. Cores 1 and 2 are intended for installation in heat pipes after the oppression layer. Cores 3 and 4 are intended for installation in thermosyphons without oppression or heat pipes under the oppression layer. Cores 1 and 2 are intended for thermosyphons and tubes with an orientation in space close to vertical, and cores 3 and 4 are for heat pipes with an arbitrary orientation. The calculation of hysteresis losses, Foucault currents and resonant losses was not performed, since the core materials do not have defined values of relative magnetic permeability and maximum induction.

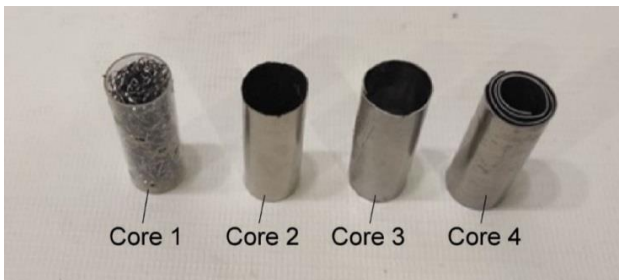

Fig. 3. External appearance of the cores used in the studies.

2.2. Research methods

The structural diagram of the experimental setup is

shown in Fig. 4.

To reduce the power of the set frequency by the pulse generator, an Arduino UNO microcontroller board was selected, into the final port of which the set frequency was entered from the PC keyboard via a USB cable. A rectangular signal of a fixed frequency comes from pulse-width modulation (PWM) output #9 of the microcontroller board. One signal amplitude of 5 was insufficient for normal operation of the power key on hollow transistors VT4. Therefore, a cascade with a fixed base flux on bipolar transistors VT1, resistors R1 – R3 and a decoupling capacitor C1 was used for connection. This cascade increased the signal to 10 V, but then reduced the number of pulses on the fronts. To form steep fronts and slopes of pulses, a Schmitt trigger on CMOS logic elements DD1, DD2 (microcircuit CD4001A) and resistors R5 is included. Resistor R4 is used to close the cascade on transistors VT1 with a Schmitt trigger. Parallel connection of elements DD3 and DD4 is used to combine the output of the Schmitt trigger with the cascade connection of the flux on transistors VT1, VT2. Resistor R8 is connected to the flow connection cascade with the power key VT4. Resistor R8 matches the output of the current amplification stage with the power key VT4. The load of this key is the inductance coil L1, to which the +12 V supply is supplied from the AC/DS converter. All amplifier stages are supplied with a stabilized voltage of +10 V from the same converter. The supply voltage of +5 V is supplied to the microcontroller board from the PC via a USB cable. Such a scheme of the experimental setup allows us to obtain a simple and reliable control system for the induction coil.

The following measuring devices were used during the experiments. To control the power consumption of the signal amplifier and the inductance coil – the PW1 wattmeter. To control the shape of the signal at the input of the VT1 power switch and on the L1 coil – the PS1 oscilloscope. To control the temperature of the power switch – the BK1 thermocouple with the PV2 millivoltmeter. To control the temperature of the coolant inside the tube – the BK2 thermocouple immersed in the coolant near its upper level and the PV1 millivoltmeter. To measure the temperature of the liquid phase of the coolant, a vacuum was not maintained in the middle of the heat pipe.

The external appearance of the experimental setup is shown in Fig. 5.

Table 1.

Parameters of cores for the pilot plant.

Core number	Type of core	Placement in the tube	Diameter, mm	Wall thickness, mm	Length, mm	Weight, g	Material
Core 1	From spiral weaving	After the wick layer	13.4	-	38	2	Stainless steel AISI 430
Core 2	Cylindrical thin-walled	After the wick layer	13.4	0.35	38	2.7	Structural steel B3
Core 3	Cylindrical thick-walled	Under the wick layer	15.4	0.45	38	5	Structural steel B3
Core 4	Cylindrical thick-walled multilayer	Under the wick layer	15.4	0.45	38	15	Structural steel B3

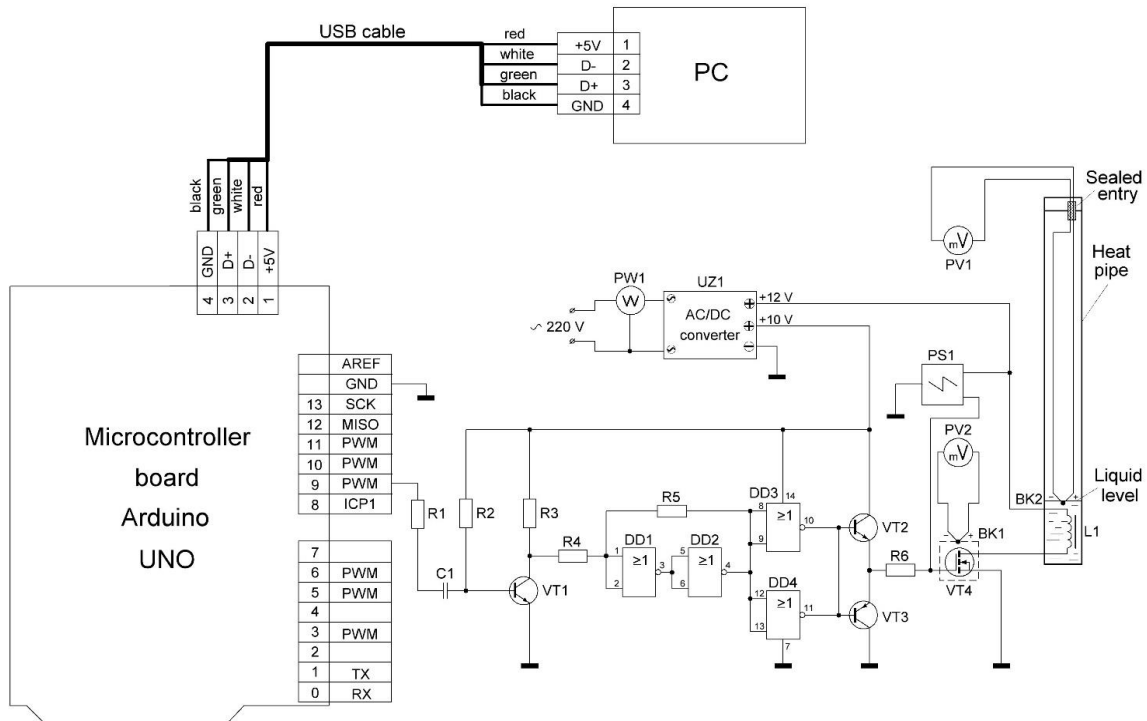

Fig. 4. Structural diagram of the experimental setup.

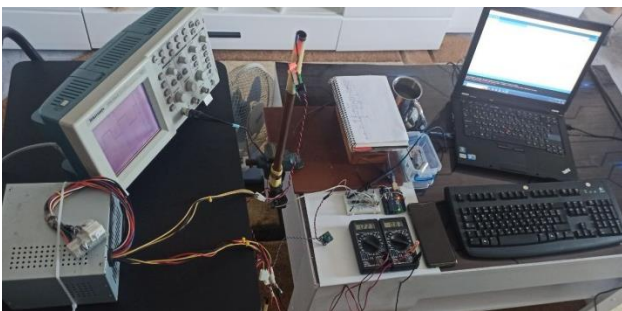

Fig. 5. General view of the experimental setup.

The aim of the experiments was to identify the efficiency of induction heating of a certain volume of coolant by each of the cores at different frequencies of a unipolar rectangular signal. An octave series of frequencies was used: 63, 125, 250, 500, 1000, 2000, 4000, 8000 Hz. The signal duty cycle was 50 %.

To conduct the experiments, the experimental heat pipe was placed strictly vertically, one of the four cores was placed in it and 10 mg of distilled water was poured in, which serves as a coolant in copper heat pipes. The research process was divided into time intervals of 15 minutes, during which every 30 seconds the change in the surface temperature of the coolant and the power consumption at each given frequency were recorded. Separately, every 5 minutes the temperature of the power key radiator was recorded.

III. Research results

The measurements were carried out at initial coolant temperatures of +25.5 °C and ambient air temperature of 23+1 °C. The results of the studies are presented in Fig. 6.

The nonlinear nature of the obtained curves is due to

the influence of heat flows from the heated core to the coolant, from the coolant to the inner wall of the tube, from the inner wall of the tube to the outer wall, from the outer wall of the tube to the environment. In the first minutes of measurements, the coolant heats up quickly, and the cold wall of the tube at its location heats up slowly, so the intensity of heating of the coolant is the highest. Over time, due to the high thermal conductivity of copper, the heating area of the tube increases, which takes up more thermal energy of the coolant, because of which the intensity of its heating decreases. A further decrease in the intensity of heating of the coolant is due to an increase in heat exchange between the heated surface of the tube and the environment.

As can be seen from Fig. 6, the highest efficiency of induction heating of the coolant by core 1 was observed at a frequency of 125 Hz, by core 2 – at a frequency of 63 Hz, by core 3 – at a frequency of 125 Hz, by core 4 – at a frequency of 250 Hz. In this case, the temperatures and intensities of heating of the coolant were different. In our opinion, this is primarily due to resonance phenomena that lead to a significant increase in currents in the core, which, accordingly, leads to its strong heating, as well as the shape of the coil excitation signal, since rectangular pulses contain harmonics that can cause resonances at certain frequencies. Thin-walled solid cores heat up faster due to a smaller thermal mass and have a higher rate of heat transfer to the coolant through a thin wall. Additional heating of the coil wire and core is caused by the supply of unipolar pulses to the coil. However, due to the low thermal resistance of the layers of electrical insulation of the coil, its wire did not heat up much, since most of the heat it released was absorbed by the surface of the experimental tube, dissipating it into the surrounding environment.

The power consumption of the electric current by the coil when working with each core varied within narrow

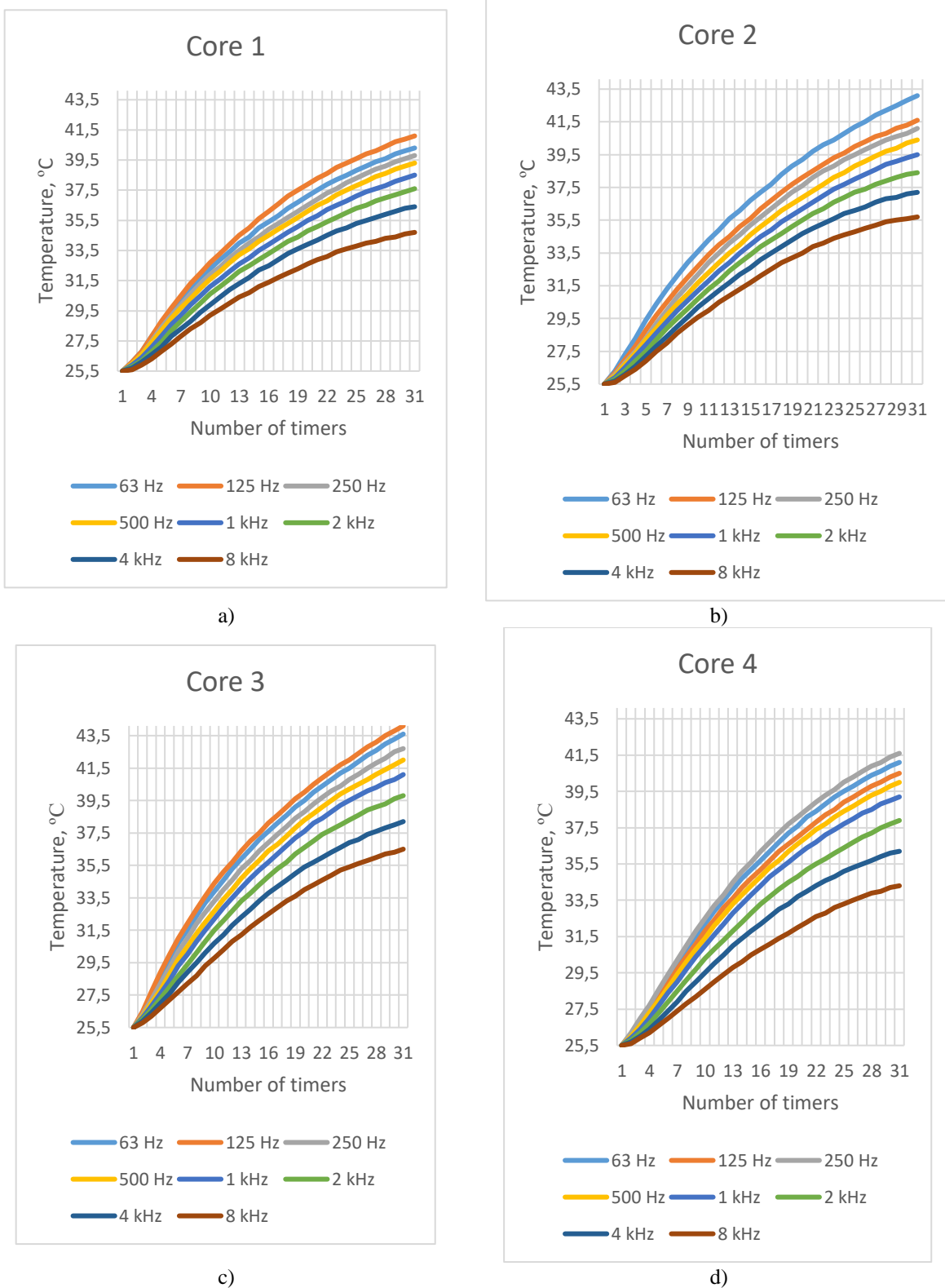

Fig. 6. Results of the study of the efficiency of induction heating with different cores.

limits. For core 1, the maximum power was 11 W at a frequency of 125 Hz, the minimum was 8.7 W at a frequency of 8 kHz. For core 2, the maximum power was 10.8 W at a frequency of 63 Hz, the minimum was 8.4 W at a frequency of 8 kHz. For core 3, the maximum power was 10.9 W at a frequency of 125 Hz, the minimum was 8.7 W at a frequency of 8 kHz. For core 4, the maximum power was 11 W at a frequency of 250 Hz, the minimum

was 8.9 W at a frequency of 8 kHz. The average power values at each frequency are given here, since they decreased as the coil warmed up and the resistance increased.

Therefore, the maximum heating intensity for 1 min is (Fig. 7): core 1 – 1 °C (counts 3-5), core 2 – 1 °C (counts 4-5), core 3 – 1.2 °C (counts 3-4), core 4 – 0.9 °C (counts 4-5). Cores 1 and 4 have almost the same heating intensity

at resonant frequencies. At the same time, core 4 is 7.5 times heavier than core 1, and the power consumption is almost the same – 11 W, which indicates that it is inappropriate to use heavy cores.

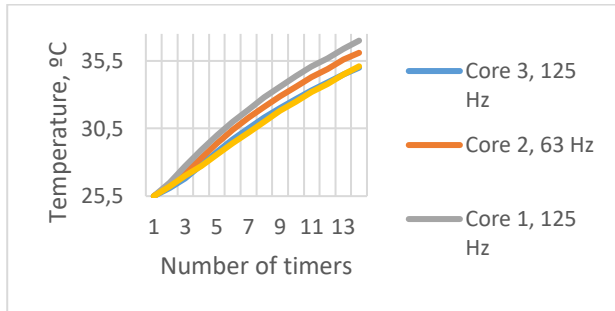

Fig. 7. Maximum heating intensities of the cores.

The graph of the power switch temperature change is not provided, since it practically did not heat up and only in the 8 kHz frequency zone a slight increase in temperature by 3 °C was recorded. A separate experiment was conducted to control the heating of the power switch at frequencies of 16 and 32 kHz, which showed an increase in its temperature by 4 and 10 °C. This showed that in the low-frequency zone the power switch can be used without a radiator. In addition, the heat pipe itself can serve as a radiator for the power switch, since its maximum permissible operating temperature (+150 °C) is significantly higher than the maximum operating temperature of the heat pipe (+50 °C).

Conclusions

As a result of the research, it was established that for heat pipes with orientation in space close to vertical, the highest temperature, the highest intensity of heating of the coolant, and, accordingly, the highest efficiency of induction heating is provided by a cylindrical single-layer core made of structural steel, located under the oppression layer at the walls of the tube. With a decrease in the wall thickness of the core, the efficiency of induction heating

increases due to its low thermal inertia. Also, the efficiency of induction heating increases with an increase in the ratio of the area of the cylindrical core to its volume and an increase in the radius.

For heat pipes with arbitrary orientation in space, high efficiency of induction heating is also provided by a cylindrical single-layer core made of structural steel, placed after the oppression layer.

A spiral weave core made of ferromagnetic stainless steel provides lower efficiency of induction heating, but due to the uniform distribution of the coolant in the volume, it ensures its uniform evaporation and optimal operation of the heat pipe. In addition, such a core has high corrosion resistance, which significantly extends the service life of the heat pipe. Low efficiency of induction heating with a stainless-steel core is due to the fact that it is not solid but dispersed throughout the volume of the plastic capsule.

In general, in our opinion, the highest operational reliability and high efficiency of induction heating of heat pipes with various orientations in space can be provided by a solid cylindrical core, or a spiral weave core made of magnetic stainless steel AISI 430 or 439, wound on a thin-walled heat-resistant plastic with holes for the movement of the coolant. The maximum radius and minimum mass of the core should provide the highest intensity of heating of the coolant per unit of time. The authors plan to manufacture such cores in the future and study their real efficiency in copper and stainless-steel heat pipes.

Vashchyshak I.R. – Candidate of Technical Sciences, Associate Professor of the Department of Energy Management and Technical Diagnostics;

Vashchyshak S.P. – Candidate of Technical Sciences, Associate Professor, Head of the Department of Information Technologies;

Mazur T.M. – Doctor of Philosophy, Associate Professor of the Department of Physical and Mathematical Sciences;

Mazur M.P. – Associate Professor, Ph.D (Physics and Mathematics), Director of the Institute of architecture, Construction and Power Engineering.

- [1] P.M.E. Vijayakumar, S. Sajairaj, R. Santhoshkumar, *Review on conventional, modern heat pipes and its applications*, International Research Journal of Engineering and Technology, 3(10), 513 (2016); <https://www.irjet.net/archives/V3/i10/IRJET-V3I1099.pdf>.
- [2] B. Abdullahi, K. Al-dadah Raya, S. Mahmoud, *Thermosiphon Heat Pipe Technology*, IntechOpen, 1, (2019); <http://dx.doi.org/10.5772/intechopen.85410>.
- [3] S. H. Noie, M. R Sarmasti Emami, M. Khoshnoodi, *Effect of inclination angle and filling ratio on thermal performance of a two-phase closed thermosiphon under normal operating conditions*, Heat Transfer Engineering, 28(4), (2007); <https://doi.org/10.1080/01457630601122997>.
- [4] V. Prokopiv, I. Horichok, T. Mazur, O. Matkivsky, L. Turovska, *Thermoelectric materials based on samples of microdispersed PbTe and CdTe*. Proceedings of the 2018 IEEE 8th International Conference on Nanomaterials: Applications & Properties (NAP - 2018), Zatoka, Odesa Region, (2018); <https://doi.org/10.1109/NAP.2018.8915357>.
- [5] Mrs. J. Emeema. *Heat Pipes – A Review on Performance Parameters*, International Journal of Creative Research Thoughts, 6(2), 746 (2018); <https://ijcrt.org/papers/IJCRT1892456.pdf>.
- [6] V. Agarwal, S. Jain, K. Vya, G. Jain, *A Review Paper on Role of Heat Pipes in Cooling*, International Journal of Emerging Trends in Electrical and Electronics, 11(2), 154, (2015); https://www.academia.edu/29562085/A_Review_Paper_on_Role_of_Heat_Pipes_in_Cooling_CTAE_1_2_GIT_S_3_4?uc-g-sw=85697005.

- [7] I.R. Vashchyshak, S.P. Vashchyshak, V.D. Myndyuk, *Energy-efficient heating system for the premises of technological gas transportation facilities using steam-droplet heaters*, Oil and Gas Energy 2017: Int. science and technology conf., Ivano-Frankivsk, May 15-19, 2017: collection of abstracts add. – Ivano-Frankivsk, 285 (2017); <http://elar.nung.edu.ua/handle/123456789/5842>.
- [8] T. Mazur, V. Prokopiv, L. Turovska, *Quasi-chemistry of intrinsic point defects in cadmium telluride thin films*, *Molecular Crystals and Liquid Crystals*, 671(1), 85(2018); <https://doi.org/10.1080/15421406.2018.1542088>.
- [9] Abdullahi, A. El-Sayed, R. Khalid Al-Dadah, S. Mahmoud, A. Fateh Mahrous, N. Mu'az Muhammad, S. Bello Abbakar, *Experimental and Numerical Investigation of Thermosyphon Heat Pipe Performance at Various Inclination Angles*, Journal of Advanced Research in Fluid Mechanics and Thermal Sciences, 44(1), 85 (2018); https://www.researchgate.net/publication/324983581_Experimental_and_Numerical_Investigation_of_Thermosyphon_Heat_Pipe_Performance_at_Various_Inclination_Angles#fullTextFileContent.
- [10] X. Lu, Y. Li, Z. Sun, *Research Progress and Prospect of Heat Pipe Capillary Wicks*, Journal of Thermal Science and Engineering Progress, 28, 100 (2022); <http://dx.doi.org/10.5098/hmt.18.24>.
- [11] K. Keishi, M. Akio, *Experimental Study on Thermal Performance of a Loop Heat Pipe with Different Working Wick Materials*, *Energies*, 14(9), 2453 (2021); <http://dx.doi.org/10.3390/en14092453>.
- [12] V. Kopei, O. Onysko, C. Barz, P. Dašić, V. Panchuk, *Designing a multi-agent plm system for threaded connections using the principle of isomorphism of regularities of complex systems*, *Machines*, 11(2), 263 (2023); <https://doi.org/10.3390/machines11020263>.
- [13] S. H. Uddin, Md. Islam, F. Jarrar, I. Janajreh, *Experimental Study on the Effect of Water as a Working Fluid in Aluminium Heat Pipes*, Journal of Thermal & Environmental Engineering, 20 (1), (2023); <https://iasks.org/articles/ijtee-v20-i1-pp-01-05.pdf>.
- [14] R. Cai, P. Bai, H. Wang, Y. Luo, X. Cen, G. Wu, S. Li, G. Zhou, *Experimental investigation of the heat transfer performance of a novel double independent chambers casing heat pipe applied for heat dissipation at low temperatures*, Applied Thermal Engineering, 188, 116508(2021); <https://doi.org/10.1016/j.applthermaleng.2020.116508>.
- [15] J. Vaibhav, J. Harsh, M. Lakshay, *Thermodynamic Performance Evaluation of Heat Pipe*, International Journal of Advance Research and Innovation, 6(1), 55 (2018); <https://doi.org/10.51976/ijari.611810>.
- [16] D.S. Naruka, R. Dwivedi, P.K. Singh, *Experimental inquisition of heat pipe: performance evaluation for different fluids*, Experimental Heat Transfer A Journal of Thermal Energy Generation, Transport, Storage and Conversion, 1 (2020); <https://doi.org/10.1080/08916152.2020.1713254>.
- [17] R.D. Bhagat , S.R. Thakare , S.C. Makwana, *Experimentation to predict the thermal performance of conventional heat pipe with water and hydrocarbon as working fluid*, International Journal of Research in Engineering and Technology, 5(3), 1 (2016); <https://ijret.org/volumes/2016v05/i03/IJRET20160503073.pdf>.
- [18] B. Dzundza, O. Kostyuk, & T. Mazur, *Software and Hardware Complex for Study of Photoelectric Properties of Semiconductor Structures*. 2019 IEEE 39th International Conference on Electronics and Nanotechnology (ELNANO), Kyiv, 16-18 April, (2019); <https://doi.org/10.1109/ELNANO.2019.8783544>.
- [19] G.V.R. Seshagiri Rao, U. Ramakanth & Suryaprakash, *Experimental investigation of heat transfer characteristics of the heat pipe*, International Journal of Mechanical and Production Engineering Research and Development, 7(5), 209 (2017); https://www.academia.edu/35534469/EXPERIMENTAL_INVESTIGATION_OF_HEAT_TRANSFER_CHARACTERISTICS_OF_THE_HEAT_PIPE.
- [20] I. R. Vashchyshak, O.P. Vashchyshak, A.V. Yavorsky, *Ways to improve energy efficiency of buildings of oil and gas complex facilities*, Scientific Bulletin of the Ivano-Frankivsk National Technical University of Oil and Gas, 1(36), 176 (2014); <http://elar.nung.edu.ua/handle/123456789/2560>.
- [21] I.R. Vashchyshak, S.P. Vashchyshak, O.V. Popovych, E.R. Dotsenko, *Improvement of steam-droplet heaters for heating systems of premises and buildings*, Methods and devices for quality control, 39(2), 68 (2017); <http://elar.nung.edu.ua/handle/123456789/6534>.
- [22] S.P. Vashchyshak, T. Lammert, *Electronic control of the temperature regime of the steam droplet heater of the heating system*, Applied scientific and technical research: III International. science and practice conference, Ivano-Frankivsk: Academy of Technical Sciences of Ukraine (April 3-5, 2019), p. 110, Ivano-Frankivsk: Symphony forte (2019); <https://ukrtsa.org.ua/wp-content/uploads/2022/02/ConferenceUTSA2019.pdf>.
- [23] Z. Liu, D. Yuan, Y. Hao, X. Li, L. Yang, J. Yao, *Experimental study on heat transfer performance of high temperature heat pipe under axial non-uniform heat flux*, Applied Thermal Engineering, 236, 121817 (2024); <https://doi.org/10.1016/j.applthermaleng.2023.121817>.
- [24] H. Nykyforchyn, V. Kyrlyiv, O. Maksymiv, V. Kochubei, R. Boyko, V. Dovhunyk, *Wear resistance of the surface nanocrystalline structure under an action of diethyleneglycol medium*, Applied Nanoscience, 9(5), 1085 (2019); <https://doi.org/10.1007/s13204-018-0690-3>.
- [25] T. Mazur, M. Mazur, M. Haluschak, *Surface-Barrier CdTe Diodes for Photovoltaics*, Journal of Nano- and Electronic Physics, 15(2), 02004-1 (2023); [https://doi.org/10.21272/jnep.15\(2\).02006](https://doi.org/10.21272/jnep.15(2).02006).
- [26] A. Kelesoglu, N. Kanmaz, H.M. Unver, & U. Unver, *A review on the evolution of induction fluid heaters. Energy Sources, Part A: Recovery, Utilization, and Environmental Effects*, 44(3), 7949 (2022); <https://doi.org/10.1080/15567036.2022.2118906>.

І.Р. Ващишак¹, С.П. Ващишак², Т.М. Мазур¹, М.П. Мазур¹

Дослідження впливу осердя на ефективність індукційного нагрівання теплоносія низькотемпературної теплової трубки

¹*Івано Франківський національний технічний університет нафти і газу, м. Івано-Франківськ, Україна, tetiana.mazur@nung.edu.ua*

²*Університет Короля Данила, м. Івано-Франківськ, Україна*

Досліджено вплив феромагнітних матеріалів трьох осердь циліндричної форми з конструкційної сталі та осердя спірального плетення з магнітної нержавіючої сталі на ефективність індукційного нагрівання теплоносія у низькотемпературній гнітій тепловій трубці. Два осердя призначались для використання під шаром гніту, а два – за шаром гніту з нержавіючої сітки без магнітних властивостей. Досліджувалась ефективність індукційного нагрівання за допомогою циліндричної котушки, намотаної на поверхню трубки. Зібрано експериментальну установку з теплової трубки, надітої на її нижню частину циліндричної індукційної котушки, генератора імпульсів, підсилювача, силового ключа, ватметра, двох термопар та таймера. Експерименти показали, що на низькій частоті для теплових трубок з вертикальною орієнтацією зі зменшенням товщини стінки залізного циліндричного осердя та збільшенні його радіусу ефективність індукційного нагріву зростає. Для теплових трубок з довільною орієнтацією у просторі найвищу ефективність індукційного нагрівання забезпечує циліндричне тонкостінне одношарове осердя, розміщене після шару гніту. Але найвищу надійність експлуатації та високу ефективність індукційного нагрівання здатні забезпечити суцільне циліндричне осердя, або осердя спірального плетення з магнітної нержавіючої сталі AISI 430, чи 439, намотане на термостійкий пластмасовий каркас з отворами для руху теплоносія. Максимальний радіус та мінімальна маса осердя повинні забезпечити найвищу інтенсивність нагрівання теплоносія за одиницю часу.

Ключові слова: тепла трубка, індукційне нагрівання, осердя, теплоносій, частота, потужність.